

TagMaster

North America, Inc.

DATA SHEET



S1951 WinFix™

WinFix™ S1951 is a card holder used for mounting ID-tags to the inside of windscreens.

The holder is fixed to the window with a double sided tape, and has a plastic spring that holds the ID-tag in position after insertion.

WinFix™ S1951 is designed for easy removal of the ID-tag, e.g. when bringing the ID-tag from the vehicle and using the ID-tag for different purposes. It is easy to slide in the ID-tag, but since the WinFix™ has a vertical “pocket design”, there is no risk of the ID-tag falling out of the holder.

Because both the tape and the holder are transparent, it is possible to see the tag from outside through the vehicle’s window. There is some extra space in the holder to put another card in front of the ID-tag, e.g. to display separate information through the window. Plastic cards or labels in front of the ID-tag do not affect microwave reading or writing.

The adhesive is an advanced type that stands the vibrations in a car and also the high temperatures arising in sunny regions. WinFix™ S1951 is however designed to stand cold climates as well.

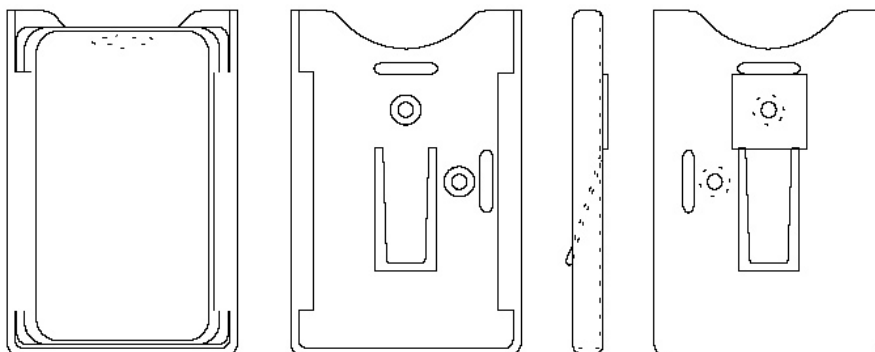

Easy to slide cards in and out
Climate and vibration resistant

Cards can be seen through the window
Space to display a separate card

DIMENSIONAL DRAWING

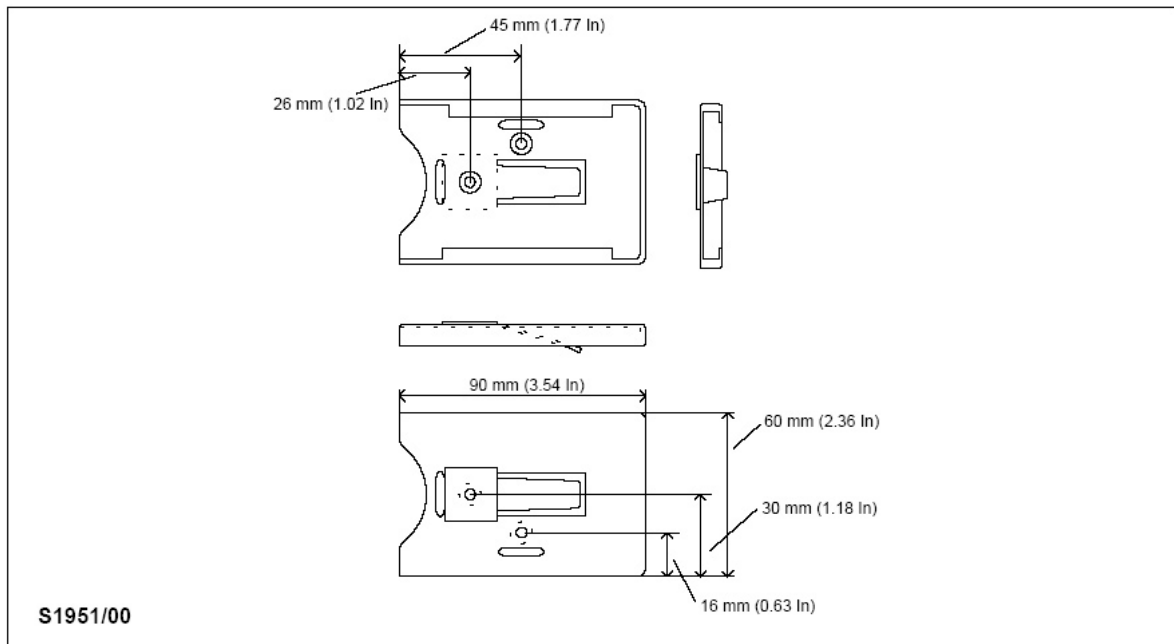

WINFIX MECHANICAL DATA

Weight	7 grams (0.25 Oz)
Dimensions	90x60x7 mm (3.54x2.36x0.28 In)
Colour Holder	Transparent
Colour Tape	Transparent
Material Holder	Polycarbonate
Material Tape	VHB 4910F, 19x19 mm (0.75x0.75 In)
Marking	The product is marked with CARDKEEP 5 in relief on the back.

THIS DOCUMENT

The information in this document is subject to change without prior notice.