

LR-Series Readers



INDEX

1	TagMaster LR-Series RFID Reader	4
1.1	High performance.....	4
1.2	Open platform based on Linux	4
1.3	Networked and Stand-alone.....	4
1.4	Reliable	5
1.5	Globally accepted.....	5
1.6	Interfaces.....	5
2	Reader model overview	5
2.1	LR-3 introduction	5
2.2	LR-6 introduction	5
3	Options	5
3.1	Reader Application software	5
3.2	Functions.....	6
3.3	Performance.....	7
4	Accessories	7
5	Reader overview	8
6	Functional description	9
6.1	RF-block	9
6.2	Controller block	9
6.2.1	System software	10
6.2.2	Application software	11
6.2.3	Protocols and interfaces	11
6.3	Mechanics	11
7	Read and write performance	12
7.1	Communication lobe diagram.....	13
8	Interfaces	14
8.1	TagMaster communication protocols	14
8.2	Other supported communication protocols.....	14
8.3	Connector interface	15
8.4	Interface isolation and protection	18
9	Performance data	18
9.1	Communication range data	18
9.2	RFID communication speed	19
9.3	Serial interfaces RS232 and RS485.....	19
9.4	USB*	19
9.5	Movement detection*	19
10	Electrical data	19
10.1	Radio	19
10.2	Power supply, J31	20
10.3	Serial interfaces RS232 and RS485, J41 – J43	20
10.4	Isolated inputs, J51	20
10.5	Isolated outputs, J52	20
10.6	Relay, J1	21
10.7	Wiegand/Mag-stripe, J2	21
10.8	USB*, P2	21
11	Mechanical data	22
11.1	LR-3 models	22
11.2	LR-6 models	24

12 Environmental specification	25
12.1 Climate	25
12.2 Mechanical	25
12.3 Electrical.....	26
13 Contact	26
13.1 Office	26

1 TagMaster LR-Series RFID Reader

The LR-Series Reader family consists of a number of different readers focused on different types of applications and installation specific requirements. The family can be divided into two main groups with the LR-3 focused on shorter distances and the LR-6s as the solution for the more demanding applications. There are mechanical and software specific differences between the two groups.

General LR-Series reader data:

- Reading range up to 10 metres
- Passage speed up to 400 km/h
- Open Linux platform. SDK available from TagMaster
- TCP/IP Networked or Stand-Alone
- Backwards compatible to Gen3 readers
- Globally accepted
- A comprehensive set of interfaces and protocols
- Low output power

1.1 High performance

TagMaster LR-Series Reader is used for long range Radio Frequency Identification (RFID) systems in the 2.45 GHz frequency band. It reads and writes information in TagMaster ID-tags by use of radio waves. The high performance of the LR-Series Reader makes it perfectly suited for demanding applications where long reading range, high passage speed, or high reading precision are required. Examples of applications are within Vehicle Access Control (VAC), factory automation and transportation. The unit is weather proof class IP66 in standard model.

1.2 Open platform based on Linux

The open LR-Series Reader platform is based on Linux which enables easy integration and adaptation to specific requirements. For this purpose TagMaster also supplies a Software Development Kit (SDK). The SDK is a complete set of tool for developing customer specific applications software, which can be downloaded to the Reader and executed in the Readers Linux environment.

The Reader also has interfaces for USB and SD memory card, which makes it possible to put in additional hardware.

1.3 Networked and Stand-alone

The TCP/IP network functionality of the LR-Series Reader enables remote operation and maintenance of the Reader.

The Reader can also operate completely stand-alone using the built-in database that stores the approved ID-tag identities. In this type of configuration the Reader can for example receive input signals from a loop detector and control a door or a barrier directly.

Three alternative Reader application software are offered where the Reader communicates over RS232, RS485 or Wiegand/Mag-stripe interfaces.

1.4 Reliable

The TagMaster LR-Series Reader is not receptive for frequencies outside the 2.45 GHz frequency band. This means that electrical noise within the KHz and MHz bands generated by electric machines and other electric equipment will not affect the performance of the reader. The robustness to disturbance is further strengthened by the use of Frequency Hopping Spread Spectrum technique (FHSS).

The LR-Series Reader operates problem-free due to the robust and well proven design. The open software and software architecture will facilitate a future upgrade if needed due to new functional requirements.

The optional Reader application software are backwards compatible with existing host applications, which make it easy to introduce LR-Series Reader also as an expansion of existing TagMaster installations. The Reader is also compatible with all TagMaster ID-tags.

1.5 Globally accepted

The TagMaster LR-Series Reader use 2.45 GHz radio frequency band to read and write information in TagMaster ID-tags. The 2.45 GHz frequency band is possible to use in most countries at low output power level without any specific site licence which enable easy installation in a wide range of applications all over the world.

The Reader meets CE and FCC requirements. It also conforms to the RoHS Directive 2002/95/EC

1.6 Interfaces

A number of different interfaces are available depending on reader model. These interfaces are used to communicate with external systems, networking the reader or collecting information from external sensors.

2 Reader model overview

2.1 LR-3 introduction

The LR-3 is focused on applications where the the demand for reading distance is limited and where the reader is part of a systems solution - meaning not operating in stand-alone mode.

2.2 LR-6 introduction

The LR-6 reader is a more flexible platform product and is capable of reading at a longer distance but also to run stand-alone applications on the Linux operating system.

3 Options

3.1 Reader Application software

WiseMan SW*	The WiseMan Software is flexible and adaptable Reader
--------------------	---

	application software, which can run stand-alone or controlled from a host. WiseMan SW comprises a database and logic to make decisions based on identified ID-tags, e.g. open a barrier when an accepted ID-tag is identified. WiseMan SW implements the ConfiTalk protocol.
WatchMan SW	The WatchMan Software operates under a host system that controls the Reader and makes decisions based on ID-tag readings from the Reader. WatchMan SW implements the ConfiTalk protocol, which is used to retrieve ID-tag information and control Reader properties. I/O ports are also handled remotely for barrier control and loop detector etc.
PassMan SW	The PassMan Software is ideal for integration with already existing access systems and configurable to support most Wiegand and Mag-stripe protocol structures.

*Not available on the LR-3 reader model

3.2 Functions

Movement Detection	The Movement Detection function detects a moving object at a distance of up to 5 metres (16 Ft). The function does not require that the object is equipped with an ID-tag. The Reader can distinguish if the object is approaching or moving away from the Reader and at what radial speed. The detection threshold can be set to different sensitivity levels.
---------------------------	---

3.3 Performance

Long writing range	Allows the Reader to write information to ID-tags at a longer distance using higher output power during the writing process. In some countries using output power at or above 10 mW may be issue to licensing.
Automatic channel detection	Applies to the FHSS* mode. The Reader listens to the environment in order to identify frequencies that are interfered by other radio sources and automatically exclude these frequencies from the hopping scheme. This will increase the performance and robustness due to the lowered risk of radio interference.

* Not available in Japan, Korea and Taiwan.

4 Accessories

SDK for user application development	<p>For user application development there is a complete Software Development Kit (SDK) including compilers, loaders, tools, drivers and function libraries supporting the complete development phase for Reader applications as well as PC applications.</p> <p>The SDK operates on a Virtual Machine that gives the complete TagMaster development environment running on Windows. The SDK is available from TagMaster.</p>
Universal Mounting Kit	A mounting kit designed for the TagMaster LR-series readers that enable mounting of readers in a wide variety of positions and angles. The kit contains all parts needed for mounting the Reader on a wall or on a pole. The Universal Mounting Kit is suitable for both indoor and outdoor use.

5 Reader overview

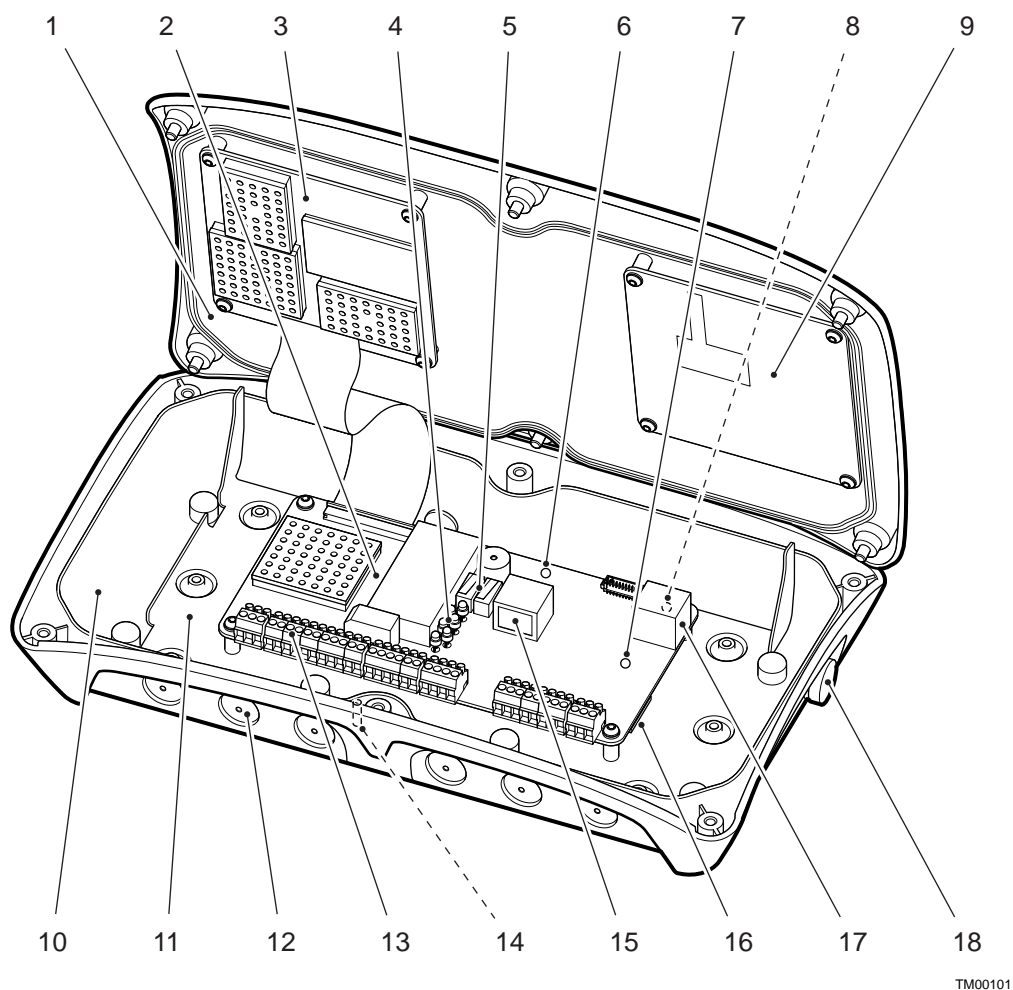

Figure 1 Overview of the Reader with open lid

The following table describes the position of the components inside the Reader.

No	Component
1	Lid
2	Controller board
3	RF-unit
4	Externally-visible indicators
5	Tamper switches
6	Red indicator
7	Green indicator
8	Yellow indicator
9	Lid

No	Component
10	Enclosure base
11	Chassis
12	Knock-out for cable entry
13	Terminal blocks
14	Ground screw
15	Ethernet connector with link state and activity indicators
16	Micro SD slot
17	USB host connector (intended for internal expansion)
18	Pressure balance membrane

6 Functional description

The reader consists of the RF-block, the controller block and the mechanics. The RF-block handles all radio functionality. The controller block includes software and the digital hardware.

6.1 RF-block

Features:

- Frequency synthesizer
- Frequency plan or frequency hopping
- High antenna directivity
- Circular polarization
- Software controlled Reading and Writing Range

The radio signal is generated in the Reader by a synthesizer that gives the exact frequency in well defined steps which are controlled from the software. The frequency can be set to 400 different radio channels to eliminate the risk of interference with other nearby Readers or other radio sources.

The LR-Series Reader can be set to operate in one of two different radio modes:

Continuous Wave (CW)	Transmitted frequency set to a fixed radio channel selected by user
Frequency Hopping Spread Spectrum (FHSS*)	Frequency hopping function which can be set to operate over the complete radio 2400-2483.5 MHz band or over selected parts of the band and automatically exclude these frequencies from the hopping scheme. This will increase the performance and robustness due to the lowered risk for radio interference.

* Not available in Japan, Korea and Taiwan.

Both modes comply with CE and FCC requirements.

The radio signal is circular polarized to enable reading with free rotation of the ID-tag as long as the front is directed towards the Reader.

The high frequency of the radio signal enables high directivity for the antennas which is used to create a well defined communication zone for reading and writing. The high directivity also makes it possible to design RFID-tags that are mounted directly on a metallic surface.

The reading range can be reduced by software command if required in a specific installation.

6.2 Controller block

Features:

- Open Platform Based on Linux
- Hardware Architecture Based on ARM9
- Web server

- Open database
- Large number of open interfaces and protocols
- Expansion Board Interface

The LR-Series Reader platform uses standard Linux operating system. Linux gives access to support for a large number of different hardware modules, applications and services. It also facilitates introduction of new hardware and software functionality into the Reader as this becomes available. Using Linux as the operating system also makes LR-Series Reader robust with a long product life time.

The microcontroller block is built around ARM9 processor core which is well proven in industrial system and is widely supported by the Linux community.

The signal processing block includes filters and decoder which are implemented in a Field Programmable Gate Array (FPGA) which enables future upgrade to new requirements.

6.2.1 System software

The system software is the foundation of the Reader software. It is the layer of the Reader software that the application software depends on. The system software consists of boot loaders, the Linux operating system, drivers, file system, utilities, the TagMaster middleware, system libraries, and servers. The system software provide functions such as web server, distributed file system support, secure remote shell and file management, database client, and text editor. It is configurable using setup files and shell scripts. With the system software it is possible to control a Reader over a network using the TAGP TCP/IP communication protocol without the need for application software in the Reader. SQLite database is included and is used for the ID-tag database.

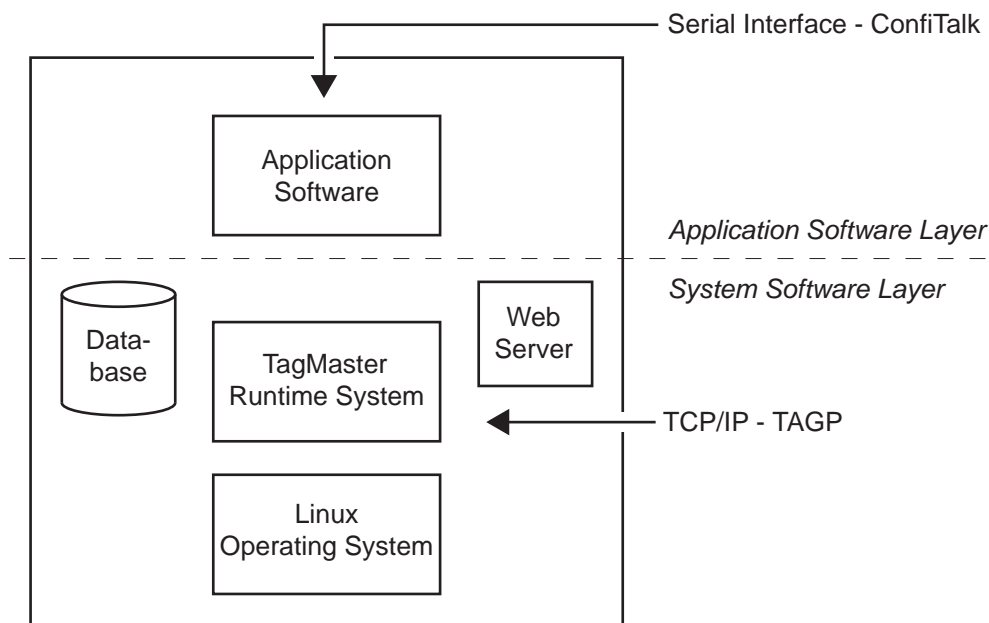

06-236 01

Figure 2 Software overview

6.2.2 Application software

There are several standard application software available from TagMaster that can be selected as an option.

The Reader is also prepared for customer specific adaptations and applications that can be developed using the Reader SDK supplied by TagMaster. The development work is facilitated by use of the function library and protocols developed and supplied by TagMaster. The SDK includes compiler and software libraries, as well as documentation.

User developed software application can be downloaded to the Reader and saved in the Flash file system over network or through a serial communication line.

6.2.3 Protocols and interfaces

The Reader supports a number of different protocols. TAGP is the TagMaster Reader protocol based on TCP/IP. ConfiTalk is a backwards compatible serial communication protocol that can be used to integrate the LR-Series Reader in existing systems or for new systems using serial communication. The LR-Series Reader also supports a number of other open standard protocols that makes it possible to handle the Reader in a secure and efficient way. This set may vary between different reader models.

The Reader has the following external interfaces for data communication:

- 10/100 Mbps Fast Ethernet
- RS485
- RS232
- Wiegand / Mag-stripe

For control of other external equipment the unit has:

- Isolated output ports
- A relay control port
- For input from sensors there are several isolated input ports available

Several interfaces can be used for connection to additional hardware:

- USB
- Micro SD Memory Card Interface
- Expansion Board Interface

These interfaces are not available in the LR-3 reader.

6.3 Mechanics

Features:

- Easy installation and service
- Polycarbonate enclosure
- Stainless steel chassis
- Weatherproof IP66 design
- Ventilated to avoid water condensation
- Mounting according to VESA 75 mm standard

LR-Series Readers are designed for public outdoor environment. The enclosure polycarbonate alloy material is robust and is capable of withstanding temperature, mechanical impact, solar radiation and chemicals. The inner chassis for mechanical support and EMC shielding is made from stainless steel. To facilitate the installation

and service the hinged Reader lid is easily opened and put into the service position which enables full access to the terminals on the Controller board.

Cable inlets are of “knock-out” type where the number and position of inlets can be selected according to the requirement for the installation. The M16x1.5 cable glands allow an RJ45 connector to be mounted outside and inserted through the opening.

The weatherproof IP66 design is ventilated by a membrane that eliminates water condensation inside the Reader. On the rear side of the enclosure base a set of M4 threads enable attachment to TagMaster Universal Mounting Kit and other VESA 75 mm standard brackets. The Reader can be mounted horizontally or vertically.

7 Read and write performance

Microwaves penetrate most non-metallic materials, such as glass, wood, plastics, gypsum, dirt and snow. The reading range may be reduced depending on any material obscuring the radio lobe between the reader and the tag.

Maximum recommended reading and writing range for LR-Series Reader :

Reading range LR-3	Up to 3 m (10 ft) as standard
Writing range	Not available at LR-3

Reading range LR-6	Up to 6 m (20 ft) as standard Up to 8 m (26 ft) with option PL1 Up to 10 m (33 ft) in model LR-6 XL
Writing range	0.25 m (0.8 ft)

The reading range can be reduced by software command or setting when this is required by the application circumstances. The system works safely at all distances down to zero.

The unit should if possible be installed and used so that free space is achieved between the ID tag and the Reader. For a typical installation in free air, it is recommended that ID-tags are passing at 60 - 70 % or less of the maximum reading and writing range as the size of the radio lobe allows for more readings of the tag during the time-period it is passing through the lobe.

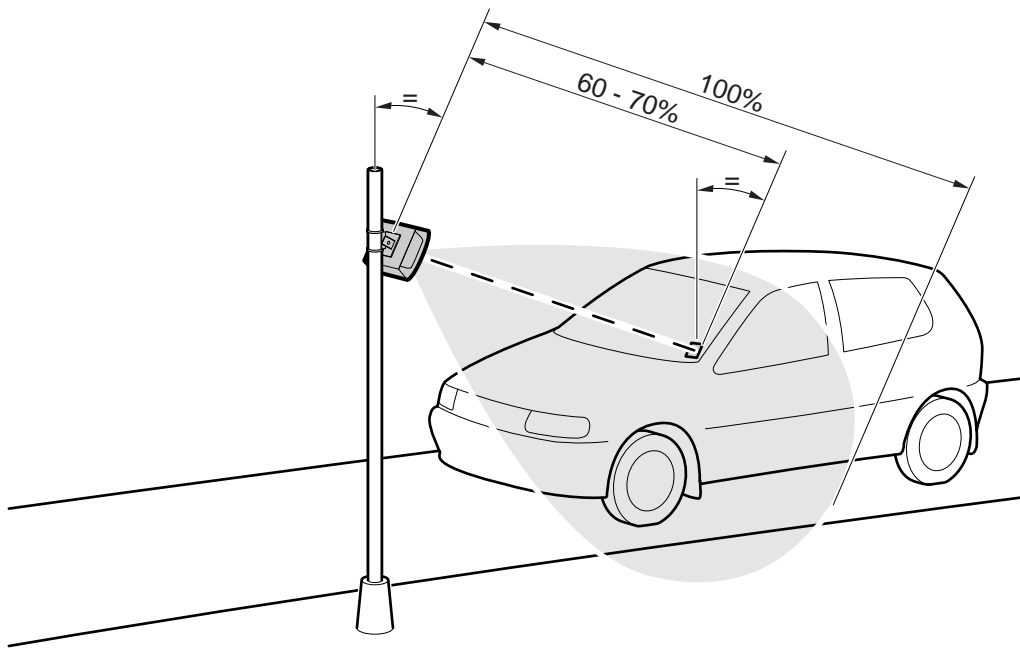

TM00103

Figure 3 Reading lobe

If large reflecting surfaces are present in the reading zone, the communication lobe may be distorted. In such case it is recommended to further shorten the distance to the ID-tag. The front side of the ID-tags must be oriented towards the front side of the Reader. For maximum communication range, the front surface of the ID-tag should be parallel with the front side of the Reader. If the ID-tag is misaligned relative to the front side of the Reader, the communication range is reduced.

If the Reader is installed with a low grazing angle to a reflecting surface such as a road or floor, the multi-path effect can increase the reading distance. If the ID tag is tilted in relation to the Reader, a reading range reduction may occur. Since these effects depend mainly on the particular installation, it is recommended that a test is made before installation is carried out.

7.1 Communication lobe diagram

The diagram below presents an example of a radio lobe characteristic when using an LR-6 with 10 mW output power. In the diagram a firm read range is given as well as the max read range of the radio lobe outside of which no readings at all are possible.

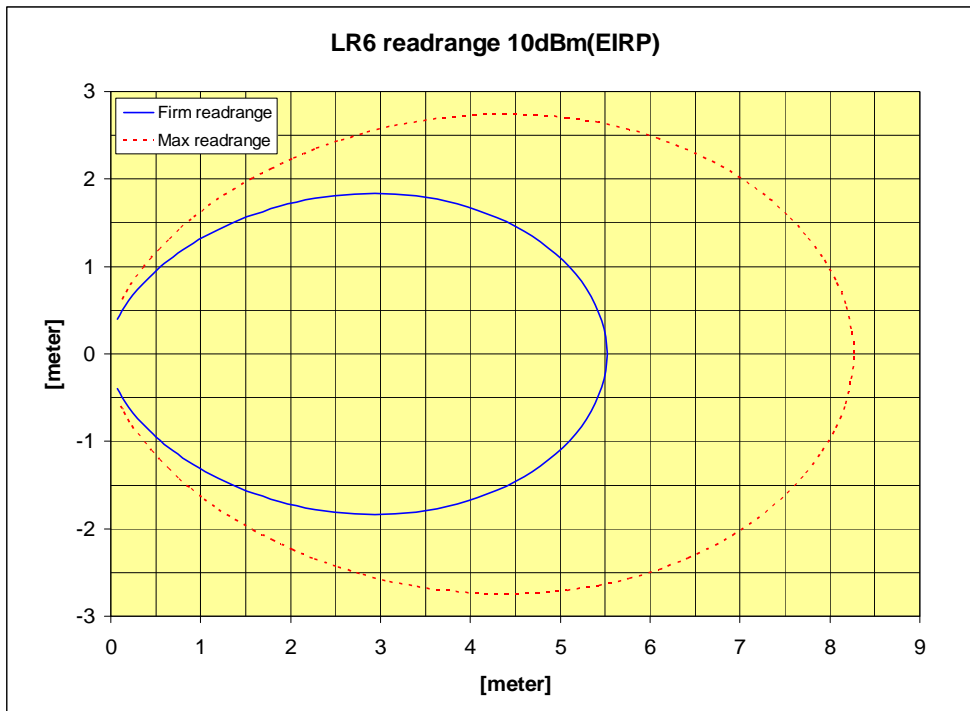

Figure 4 Schematic communication lobe diagram

The lobe diagram shows the approximate communication lobe shape along the communication axis for the LR-Series Reader. The diagram does not take into account possible influences from signal reflections or attenuation related to material penetration. For the available power level options PL1 and LR-6 XL, the range of the lobe is extended and the shape modified accordingly.

In high speed applications including for fast moving vehicles, the ID-tag should be in the high speed reading area for the time period specified in respective ID-tag data sheet. In other applications the full reading area can be used.

8 Interfaces

8.1 TagMaster communication protocols

TAGP	TagMaster Protocol is a communication protocol that is used for network communication with Readers. It is an ASCII character based protocol that uses reliable TCP/IP sockets for information transportation.
ConfiTalk	ConfiTalk is a serial communication protocol. It is a request/response protocol between host and Readers and supports addressing. It handles flow control, retransmissions, checksums and data transparency. It can be used both for point-to-point and multidrop networks, using a polling procedure. It is supported by application software WiseMan and WatchMan.

8.2 Other supported communication protocols

IP version 4	Internet Protocol is a data-oriented protocol used for communicating data across a packet-switched internetwork, e.g. Internet
TCP	Transport Control Protocol guarantees reliable and in-order delivery of data from sender to receiver. TCP also distinguishes data for multiple connections by concurrent applications running on the same host.

UDP	User Datagram Protocol is one of the core protocols of the Internet protocol suite. Using UDP, programs on networked computers can send short messages sometimes known as datagrams to one another.
SSH	Secure Shell is a set of standards and an associated network protocol that allows establishing a secure channel between the Reader from a remote host. SSH is typically used to log into the Reader and execute commands, but it also supports tunneling, and transfer of files using the associated SFTP or SCP protocols.
HTTP	Hypertext Transfer Protocol is used for communication to the web server in the Reader.
CGI	Common Gateway Interface is a standard protocol for interfacing Reader application software with the Reader web server.
NFS	Network File System is as a distributed file system which allows a Reader to access files over a network as easily as if they were on its local file system. It is mainly used for UNIX / Linux systems, though it can be used on other platforms such as Microsoft Windows, Novell NetWare, etc.
CIFS	Common Internet File System (also known as SMB) is a network protocol mainly applied to share files and printers. It is mainly used by Microsoft Windows equipped computers.
XMODEM	Serial protocol to download files via the service interface.

8.3 Connector interface

For easy installation and service the cables are screwed into removable block connectors. The function of each block is described in the figure and in the table below.

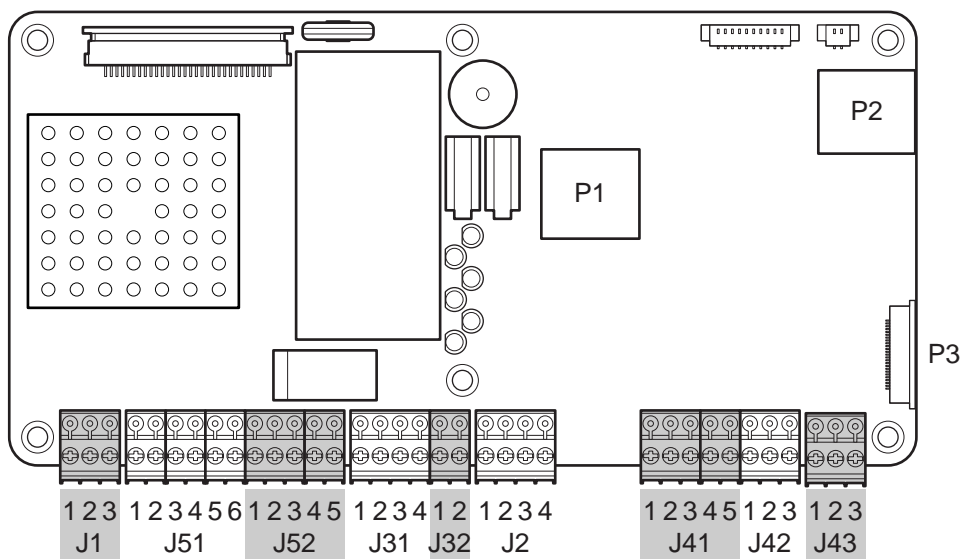

TM00107

Figure 5 Connector overview

No.	Function	Description
J1	Relay outputs	The controller board has one relay output for heavy duty loads
J51	Isolated Inputs	The Reader has three separate and isolated inputs which are activated by a current flow.
J52	Isolated Outputs	The Reader has two open collector outputs which can be used for switching an external current on and off. The OutSPL pin is a common external power supply needed for the Isolated output

		function. If there is no need for isolation, the power can be fed from J31 Power Supply pin 3 and 4.
J31	Power Supply	Pin 1 is internally connected to pin 3. Pin 2 is internally connected to pin 4. The purpose is to make it possible to feed power to any peripheral equipment. Use pins 1 and 2 for power supply connection.
J32	External Tamper Switch	To protect the Reader from tampering, there are two mechanical tampering switches which break if the cover is opened. One tamper switch is connected internally to the controller board and will generate a software alarm when broken, and the other is an external tamper switch interface which can be connected to an external alarm loop.
J2	Wiegand/ Mag-stripe	The controller board has an access control interface that supports both Wiegand and Mag-stripe protocols. The connector pins have two different functions depending of if Wiegand or Mag-stripe is used
J41	RS485 Serial Communication Interface	The controller board has one RS485 serial interface for both 2-wire and 4-wire communication. The communication can be in half duplex or full duplex. The RS485 supports also multi-drop serial networks for half duplex.
J42	RS232 Serial Communication Interface	The controller board has one RS232 serial interface for application software use.
J43	RS232 Service port Interface	The service interface can be used for maintenance and configuration of the Reader. Do not use the service interface as a regular system interface.
P1	Ethernet	Fast Ethernet 10/100 Mbps interface that supports auto-negotiation for automatic media speed and protocol selection. Indicators on the Ethernet connector indicate link/activity and link speed 10/100.
P2	USB	Two USB host interfaces that comply with the USB 2.0 Full Speed standard. They can be used as expansion interfaces for adding new functionality to the Reader meeting specific customer requirements. For instance Flash memory, GSM modem or WLAN interface. Readers are pre-installed with Linux drivers that can be used to access USB memory devices. The interfaces also supply power to the connected devices.
P3	Expansion Board Interface	It is possible to add other customer specific software via the expansion board interface.
P4	Micro SD Memory Card interface	The interface (specification version 1.0) can be used to add more memory and new functionality to a Reader. Readers are pre-installed with Linux drivers that can be used to access memory cards.

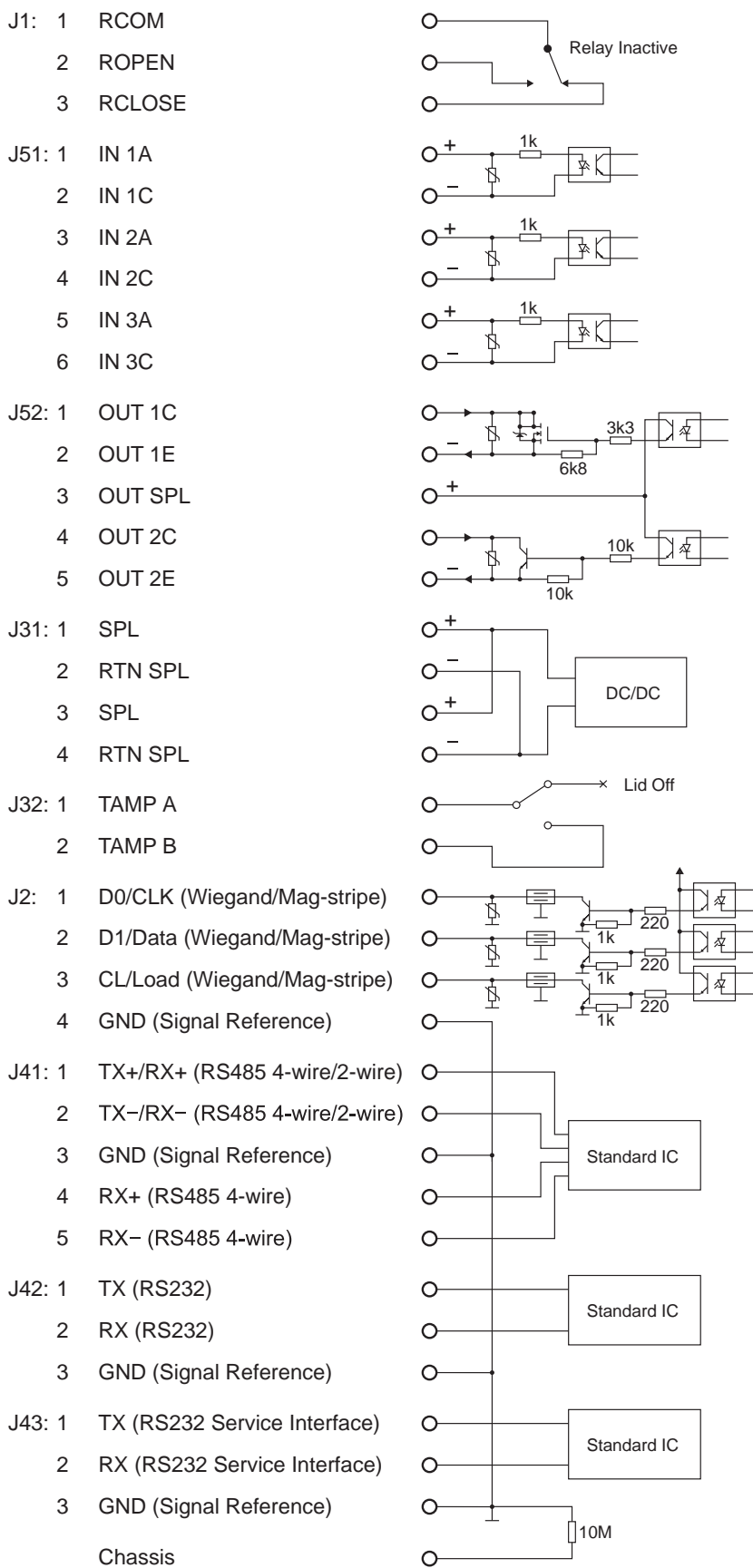

06-234 01

Figure 6 Pinning and schematic design of the Reader interfaces

8.4 Interface isolation and protection

The hardware design is protected against radiated or wired disturbances by extensive use of filters, transformers and shielding. The power input is galvanic separated from the main electronic part of the Reader by use of an on-board DC-DC converter. The Interface Block with Ethernet, Serial Interfaces and I/O signals is also galvanic isolated from the rest of the Reader. This makes sure that no ground currents will occur between shielding, power lines or other interfaces. The common GND connection in J2 and J41-J43 is a floating reference ground for the interface block signals. This makes it possible to operate the interface with the voltage potential set from the other party. The reference ground is internally connected to the chassis via a discharge resistor to avoid static voltage potential. It has no other reference to connections outside the interface block.

The USB port GND is connected to the chassis.

The Wiegand/Mag-stripe interface, the Isolated Inputs, and Isolated Outputs have a varistor protection that will short-circuit signals over rated maximum 30 V.

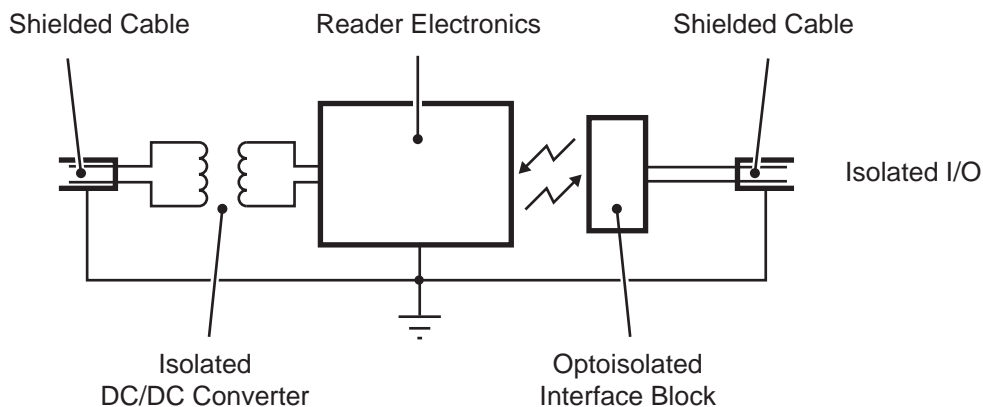

06-237 01

Figure 7 Figure shows the principal galvanic isolation

9 Performance data

9.1 Communication range data

Parameter	Value	Unit
Reading Range LR-3	Up to 3	m
	Up to 10	ft

Parameter	Value	Unit
Reading Range LR-6	Up to 10	m
Reading Range LR-6 with option PL1 (25mW)	Up to 8	m
	Up to 26	ft
Reading Range LR-6 XL	Up to 10	m
	Up to 33	ft

Writing Range	0–0.25	m
	0–0.8	ft
	0–2	ft

9.2 RFID communication speed

Parameter	Value	Unit
High Reading Data Speed	16	kbs
Low Reading Data Speed	4	kbs
Writing Data Speed	4	kbs

9.3 Serial interfaces RS232 and RS485

Parameter	Min	Max	Unit
Baud Rate	1.2	115.2	kbs

9.4 USB*

Parameter	Min	Max	Unit
Baud Rate		12	Mbs

*Not available in the LR-3 reader model

9.5 Movement detection*

Parameter	Min	Max	Unit
Movement Detection Speed	0.3	9.2	m/s
Movement Detection Range		5	m

10 Electrical data

Data regards the temperature range –40 to +60 °C or –40 to +140 °Fh.

10.1 Radio

Parameter	Value	Unit
Radio Wave Polarisation	Circular	
Output Power: LR-3 LR-6 LR-6 with PL1 option LR-6 XL	1 10 25 75	mW e.i.r.p mW e.i.r.p mW e.i.r.p mW e.i.r.p
TX Modulation	ASK	

CW-mode: Radiation Frequency	2435–2465	MHz
CW-mode: Number of RF Channels	93	
CW-mode: Channel Separation	300	KHz
FHSS-mode*: Radiation Frequency	2400–2483.5	MHz
FHSS-mode*: Number of RF Channels	400	
FHSS-mode*: Channel Separation	200	KHz

* Not available in Japan, Korea and Taiwan.

10.2 Power supply, J31

Parameter	Value	Unit	Measured between pin
DC Power Supply	10–30	V	1-2, 3-4
DC Power Consumption Typical	4.5	W	1-2, 3-4
Max DC Power Consumption with Expansion Board	15	W	1-2, 3-4
Isolation to Shielding and Chassis	1500	V	1...6 to chassis

10.3 Serial interfaces RS232 and RS485, J41 – J43

Parameter	Min	Max	Unit
Isolation to Shielding and Chassis	1500		V

10.4 Isolated inputs, J51

Parameter	Min	Max	Unit	Measured between pins
High Voltage (active)	2.4	30	V	1-2, 3-4, 5-6
Low Voltage(inactive)	0	0.2	V	1-2, 3-4, 5-6
Input Impedance	1000		Ohm	1-2, 3-4, 5-6
Isolation to Shielding and Chassis	1500		V	1...6 to chassis

10.5 Isolated outputs, J52

Parameter	Min	Max	Unit	Measured between pins
Applied Voltage Out 1,2	1	30	V	1-2, 4-5
Sink Current Out 1	0	500	mA	1-2
Sink Current Out 2	0	100	mA	4-5

Supply	12	30	V	3-2, 3-5
	3	9	mA	3-2, 3-5
Isolation to Shielding	1500		V	1...5 to chassis

10.6 Relay, J1

Parameter	Min	Max	Unit	Measured between pins
Switchch Current		2	A	1-2, 1-3
Switch Voltage DC		60	V	1-2, 1-3
Switch Voltage AC		30	Vrms	1-2, 1-3
Switch Power		50	W	1-2, 1-3
Isolation to Shielding and Chassis	1500		V	1...3 to chassis

10.7 Wiegand/Mag-stripe, J2

Parameter	Min	Max	Unit	Measured between pins
Voltage		30	V	1-4, 2-4, 3-4
Sink Current		50	mA	1-4, 2-4, 3-4
Isolation to Shielding and Chassis	1500		V	1...4 to chassis

10.8 USB*, P2

Parameter	Min	Max	Unit
Total Current Supply		500	mA

* Not available in the LR-3 reader model

11 Mechanical data

11.1 LR-3 models

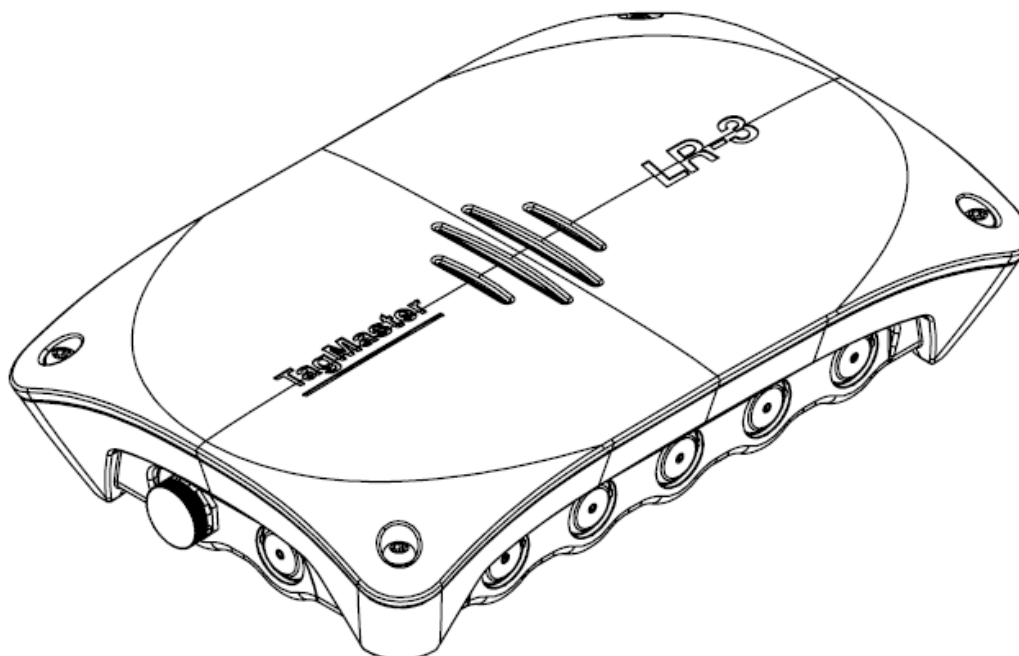

Parameter	Value	Unit
Weight	0.75	kg
	1.65	lbs
Dimensions	226*143*50	mm
	8.9*5.6*2.0	in
Enclosure Material	PC-PBT and PC (Xenoy)	
Chassis Material	Stainless steel	
Sealing	Rubber Gasket	
Colour: Enclosure Base	Dark Grey RAL7024	
Colour: Lid	Medium Grey NCS S 6502-B	
Indicators	Red, Green, and Combined (Yellow)	
Cable Entry Fittings	M16x1.5 IP67	
Cable Screw terminals	AWG 26 – 16	Cable Screw terminals
Fixing Holes	M4x8 mm length	

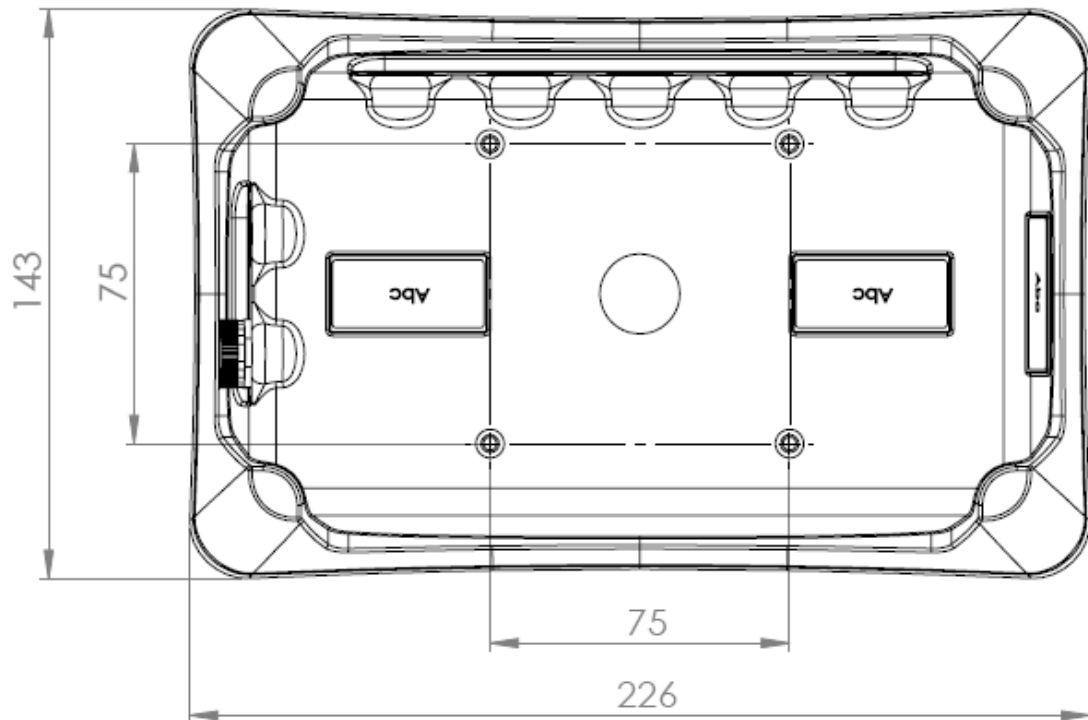

Figure 8 LR-3 backside with mounting hole layout (units of measurement: mm)

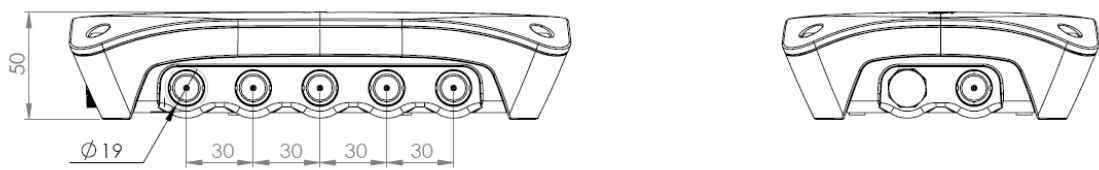

Figure 9 Side views showing 5 knock-outs for cables and the Gore-Tex type of membrane for ventilation

11.2 LR-6 models

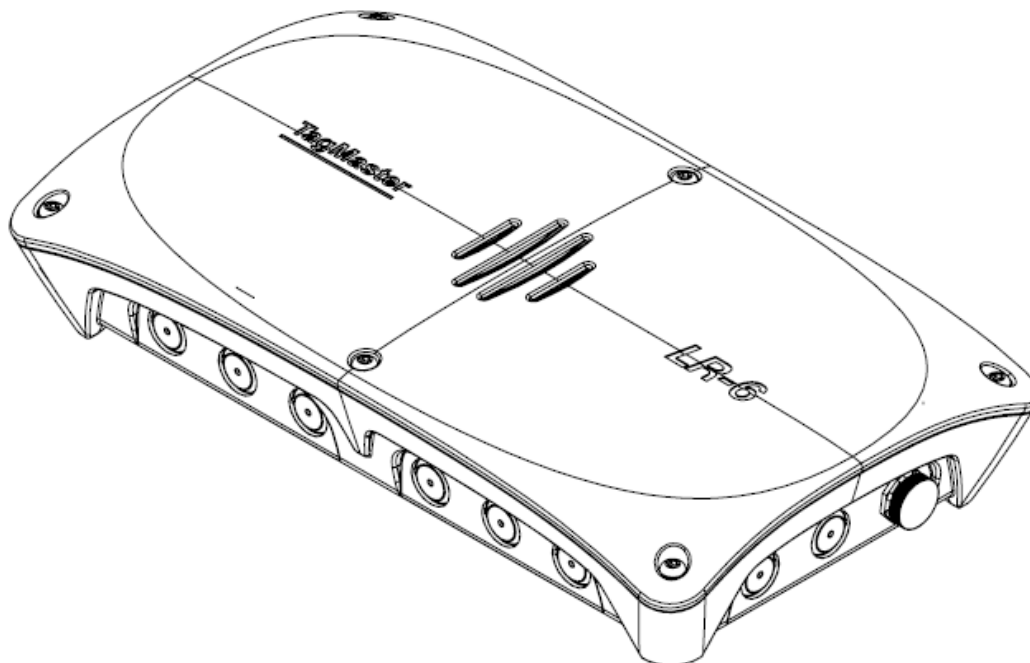

Figure 10 Front with light indicator.

Parameter	Value	Unit
Weight	1.0	kg
	2.2	lbs
Dimensions	290x165x55	mm
	11.4x6.5x2.2	in
Enclosure Material	PC-PBT and PC (Xenoy)	
Chassis Material	Stainless steel	
Sealing	Rubber Gasket	
Colour: Enclosure Base	Dark Grey RAL7024	
Colour: Lid	Medium Grey NCS S 6502-B	
Indicators	Red, Green, and Combined (Yellow)	
Cable Entry Fittings	M16x1.5 IP67	
Cable Screw terminals	AWG 26 – 16	Cable Screw terminals
Fixing Holes	M4x8 mm length	

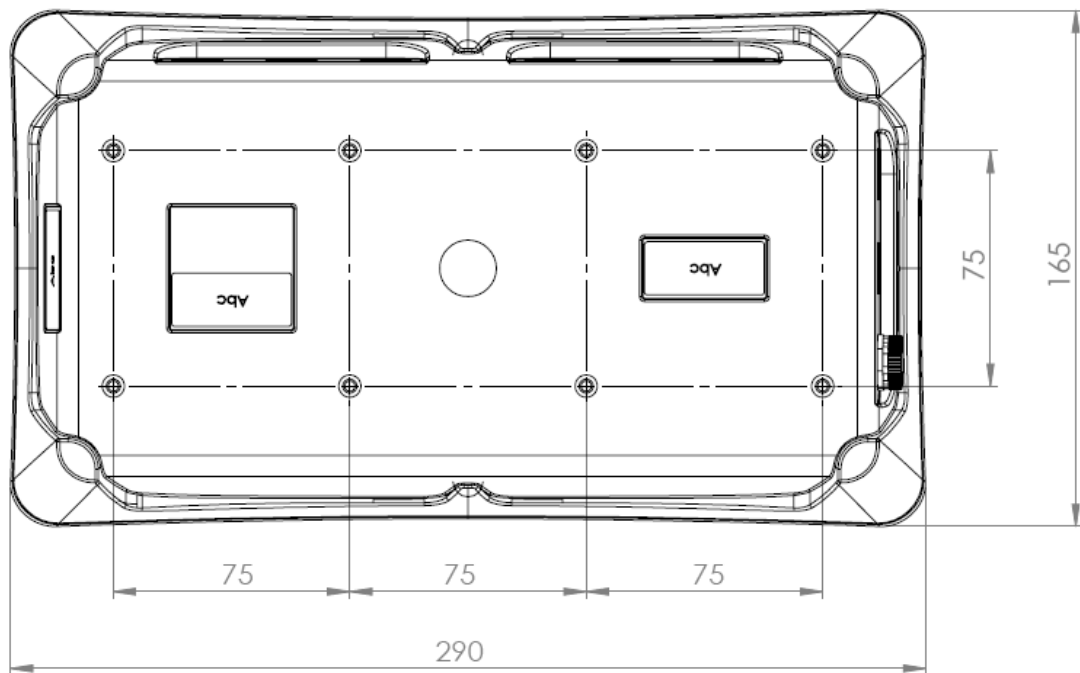

Figure 11 LR-6 backside with 3 alternative VESA 75 mounting positions.

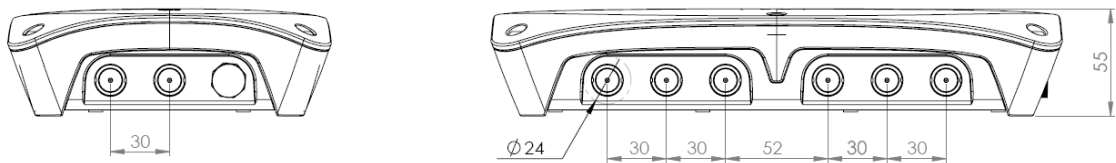

Figure 12 Side views showing 8 knock-outs for cables and the Gore-Tex type of membrane for ventilation.

12 Environmental specification

12.1 Climate

Parameter	Value	Reference
Cold	-40°C or -40°Fh	IEC68-2-1 Ad
Heat	+60°C or +140°Fh	IEC68-2-2 Bd
Sealing	IP66	IEC 60 529

12.2 Mechanical

Parameter	Value	Reference
Shock	30 G, 6 ms, 10x3 dir	IEC68-2-27 Ea
Bump	25 G, 6 ms, 1000x3 dir	IEC68-2-29 Eb

Random Vibration		IEC 60068-2-64
------------------	--	----------------

LR-Series Reader complies with RoHS Directive 2002/95/EC

12.3 Electrical

Parameter	Reference
Immunity	Acc. to CE: EN 301 489-3
Emission	Acc. to CE: EN 300 440-2 FCC part 15 subpart B and C Class A digital equipment
Safety	EN/IEC 60 950-1

Note – This equipment has been tested and found to comply with the limits for a Class A digital device, pursuant to Part 15 of the FCC Rules. These limits are designed to provide reasonable protection against harmful interference when the equipment is operated in a commercial, industrial or business environment. If not installed and used in accordance with the LR-series Installation Manual the equipment may cause interference to radio communications in which case the user will be required to correct the interference at his own expense.

Warning – To comply with Council Recommendation 1999/519/EC, it is recommended that the reader is installed so that a separation distance of at least 20 cm (8 in) from all persons is provided.

13 Contact

For any further inquiries, please contact TagMaster North America, Inc.

13.1 Office

TagMaster North America, Inc.
15 Oregon Ave., Ste 305
Tacoma, WA 98409, USA

Phone: (253) 238-1421
Support: (253) 471-2731
Fax: (253) 238-7762
sales@tagmasterna.com
support@tagmasterna.com
www.tagmasterna.com

Copyright

The copyright and ownership of this document belongs to TagMaster AB. The document may be downloaded or copied provided that all copies contain the full information from the complete document. All other copying requires a written approval from TagMaster AB.

Disclaimer

While large effort has been taken to ensure the accuracy of the information in this document TagMaster AB assume no responsibility for any errors or omissions, or for damages resulting from the use of the information contained herein. The information in this document is subject to change without notice.